

INSTANT-VIEW[®] PSA Semi Quantitative Serum Test (Cassette)

Simple Assay
Rapid Visual Results
For Qualitative In Vitro Diagnostic Use

INTENDED USE

The INSTANT-VIEW[®] PSA Rapid Test is a rapid lateral flow, semi-quantitative immunoassay. It is intended for use at point of care facilities to measure total prostate specific antigen (tPSA) in human serum at a cutoff level of 4 ng/ml and with an analytical sensitivity of 1 ng/ml. Test results are to be used with other data by a physician as an aid to diagnosing prostatic disease, monitoring the response of patients to therapy or detecting recurrent or residual disease in patients.

SUMMARY AND EXPLANATION

Prostate Specific Antigen (PSA) is an organ-specific antigen secreted primarily by the epithelial cells in the acini and ducts of the prostate gland. It may increase or decrease with changes in prostatic disease burden. Normally, the level of total PSA (tPSA) in human serum is in the range of 0.1~2.6 ng/ml. The common pathological cutoff level of tPSA in human serum is 4 ng/ml. Elevated serum tPSA is one of the important markers for prostate pathologies, such as benign prostatic hyperplasia (BPH), prostatitis, and prostate cancer.

Prostate cancer is the most prevalent cancer in men. According to the American Cancer Society, Prostate cancer is the second-leading cause of cancer death among men in the country. Autopsy studies have shown that approximately one in three men over the age of 50 years has histological evidence of prostate cancer, with up to 80% of these tumors being microscopic in size or clinically insignificant. Fortunately, only about 3% of men will die from this disease.

This proposed device is a semi-quantitative tPSA test for human whole blood or serum. It is a noninvasive method; the assay procedures are easy and do not require professional training; it provides a rapid result.

TEST PRINCIPLE

This assay is a chromatographic lateral flow, semi-quantitative immunoassay. The test strip in the device consists of 1) a burgundy-colored conjugate pad containing colloidal gold coupled with mouse anti-human tPSA antibodies, and 2) nitrocellulose membrane containing a test (T) line, a reference (R) line, and a control (C) line. The T line is coated with mouse anti-human tPSA antibodies, the R line is coated with goat anti-chicken antibodies, and the C line is coated with goat anti-mouse antibodies.

The C line should always appear within 4 minutes, regardless of the presence of tPSA in the specimen. It serves as an internal qualitative control of the test system to indicate that an adequate specimen volume has been applied and the liquid migration occurred properly.

The appearance of T line depends on the concentration of tPSA in the specimen tested. If a specimen does not contain tPSA or contains tPSA below 1 ng/ml, the T line will not develop within 4-7 minutes, indicating a negative result; if a specimen contains tPSA at a level higher than 1 ng/ml, the T line will appear, indicating a positive result.

The R line, as the C line, should always appear within 4 minutes, regardless of the presence of tPSA in the specimen. The R line serves as a criterion to indicate the concentration of tPSA is at 4 ng/ml. If the concentration of tPSA in the specimen is less than 4 ng/ml, the color intensity of T line will be weaker than that of the R line; if the concentration is higher than 4 ng/ml, the color intensity of T line will be stronger than that of the R line; if a specimen contains tPSA at a level around 4 ng/ml, the color intensity of T line is equivalent to that of the R line.

MATERIALS AND REAGENTS PROVIDED

- 25 test devices, each sealed in a pouch with a dropper pipette and a desiccant.
- 1 Package Insert (Instructions for Use)

MATERIAL REQUESTED BUT NOT PROVIDED

- Specimen containers
- Timer

STORAGE

Store the kit at room temperature 15-30°C (59-86°F). Each device may be used until the expiration date printed on the label if it remains sealed in its foil pouch containing desiccant.

Exposing the kit to the temperatures over 30°C may reduce the shelf life of the device or even damage the device. Freezing to -70°C (-94°F) will not cause damage to the device.

Do not expose the kit to temperatures over 30°C (86°F).



PRECAUTION

1. This kit is for professional in vitro diagnostic use only.
2. Do not pipette any material by mouth. Do not smoke, eat or drink in areas where specimens or reagents are handled.
3. Appropriate precautions are necessary in the collection and handling of specimens. Individuals performing the test should wear protective clothing such as laboratory coats and disposable gloves while collecting and testing samples and thoroughly wash hands afterwards.

4. Use a separate disposable pipette and test device for each specimen.
5. All spills should be wiped up thoroughly with sodium hypochlorite (0.5%), alcohol (70%) or an iodophor disinfectant.
6. Dispose of all specimens and used assay materials as biohazardous.
7. Avoid any contact between hands and eyes and nose during specimen collection and testing.
8. Do not mix reagents or components from different lots of test kits.
9. Do not use expired devices.

SPECIMEN COLLECTION AND STORAGE

1. Follow standard laboratory procedures to collect serum specimens.
2. Serum specimens can be stored at 8-30°C (46-86°F) for 8 hours, at 2-8°C (36-46°F) for one week, and at -20°C (-4°F) or lower for prolonged storage. Repeatedly frozen and thawed specimens are not recommended for this assay.
3. Any sediment in serum specimens should be removed by centrifugation. Avoid using any turbid specimens, which may be contaminated by microorganisms.

ASSAY PROCEDURE

1. Refrigerated specimens and other test materials, including devices, **must be equilibrated to room temperature before testing.**
2. Remove the device from its pouch and label the device with specimen identification.
3. Holding the dropper vertically, add three drops of fresh serum to the sample well marked "S".
4. Strong positive results may be observed in 2-3 minutes. Weak positive results may take a longer time. The results should be read within 4-7 minutes.
DO NOT INTERPRET THE RESULTS AFTER 7 MINUTES.

INTERPRETATION OF RESULTS

Positive: A positive result indicates the detection of PSA in the ranges identified below but does not confirm a pathological state.

- A. If all three lines are present, and the intensity of the T line is weaker than that of the R line, the test indicate a positive result: the level of tPSA is around or above 1 ng/ml but below 4 ng/ml.

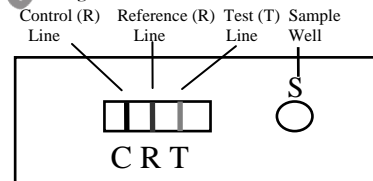

- B. If all three lines are present, and the intensity of the T line is close to that of the R line, the test indicate a positive result: the level of tPSA in the specimens is about 4 ng/ml.

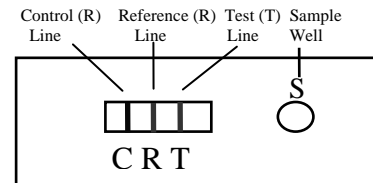

- C. If all three lines are present, and the intensity of the T line is stronger than that of the R line, the test indicate a positive result: the level of tPSA in the specimens is above 4 ng/ml.

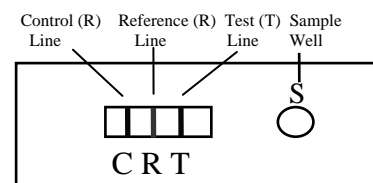

Negative: If only the C line and the R line, but no T line are present, the test indicates a negative result: the concentration of tPSA in the specimen is below 1 ng/ml.

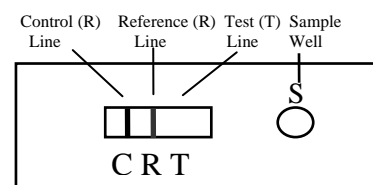

INSTANT-VIEW[®] PSA Semi Quantitative Serum Test (Cassette)

Invalid:

If the C line and/or the R line do not appear within 5 minutes, the test is invalid. Repeat the assay with a new test device.

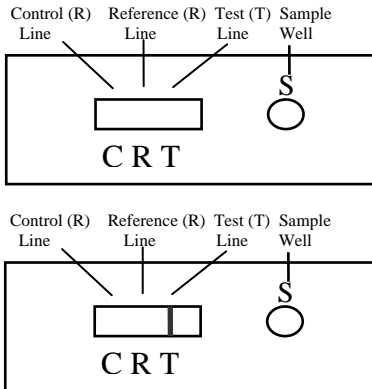

QUALITY CONTROL PROCEDURE

Built-in Control Features

This test contains a built-in quality control feature, the C line. The appearance of the burgundy C line indicates that an adequate volume of specimen has been applied and the liquid migration occurred properly.

External Quality Control

External controls are recommended, positive and negative, to monitor the proper performance of the assay.

LIMITATIONS

This kit is designed as an aid in screening and monitoring, and should not be taken as a final diagnostic result.

PERFORMANCE CHARACTERISTICS

A. Analytical Sensitivity

The analytical sensitivity of this device is 1 ng/ml. The cutoff concentration of this test is 4 ng/ml.

B. Relative Sensitivity and Specificity

Three hundred and three (303) clinical serum specimens and nine (9) diluted specimens were used for this study. There were one hundred and ninety-two (192) positive and one hundred and twenty (120) negative. All the specimens were blind labeled and tested in house. One hundred and ninety-one (191) out of one hundred and ninety-two (192) positive clinical specimens were detected, and one hundred and seventeen (117) out of one hundred and twenty (120) negative clinical specimens were detected. These results gave a sensitivity of 99.5% and a specificity of 97.5% for this device.

		Clinical sample		Total
		Positive	Negative	
Instant View [®]	Positive	191	3	194
PSA Rapid Test	Negative	1	117	118
Total		192	120	312

C. Clinical Evaluation

A panel of eighty (80) tPSA-spiked serum samples were tested with this device at three physician's office laboratories (POL) by personnel with diverse educational backgrounds and work experiences. The samples were evenly distributed at four different concentrations, 0, 2, 6, and 20 ng/ml. The results were presented in the table below.

		POL1	POL2	POL3	Expected Result
Spiked Whole Blood Samples	0 ng/ml	20-	20-	20-	20-
	2 ng/ml	20-	20-	20-	20-
	6 ng/ml	20+	20+	20+	20+
	20 ng/ml	20+	20+	20+	20+
Agreement		100%	100%	100%	
Overall Agreement		100%			

As shown in the table, the agreement for spiked serum samples was 100% at all three POLs.

D. Cross Reactivity and Interference

1. The device was tested for cross reactivity with the substances listed in the table below. They are protease inhibitors in the same family as PSA and have high homology with PSA. These substances were spiked into the PSA weak positive and negative specimens, accordingly, at 5.0 µg/ml (higher than normally

present in patient sera). There was no effect on the test results, positive or negative, suggesting that none of these proteins cross-react with this assay.

Analytes	Concentration	Specimens	
		(Positive) +	(Negative) -
Kallikrein	5.0 g/ml	+	-
Trypsin	5.0 g/ml	+	-
Chymotrypsin	5.0 g/ml	+	-

2. The potentially cross-reactive endogenous substances (including common serum components, such as lipids, hemoglobin, Bilirubin etc.) at high concentrations were spiked into the PSA weak positive and negative specimens and tested accordingly. No cross reactivity or interference was observed to the device at the concentrations displayed in the table below.

Analytes	Concentration	Specimens	
		(Positive) +	(Negative) -
Albumin	20 mg/ml	+	-
Bilirubin	10 g/ml	+	-
Hemoglobin	15 mg/ml	+	-
Glucose	20 mg/ml	+	-
Uric Acid	200 g/ml	+	-
Lipids	20 mg/ml	+	-

3. Some other Common Biological Analytes were spiked into the PSA positive and negative specimens and tested separately. There were no significant interferences observed at the level displayed in the table below.

Analytes	Concentration	Specimens	
		(Positive) +	(Negative) -
Acetaminophen	200 g/ml	+	-
Acetoacetic Acid	200 g/ml	+	-
Acetylsalicylic Acid	200 g/ml	+	-
Benzoyllecgonine	100 g/ml	+	-
Caffeine	200 g/ml	+	-
DMSO	5 %	+	-
EDTA	800 g/ml	+	-
Ethanol	1.0 %	+	-
Gentisic Acid	200 g/ml	+	-
β - Hydroxybutyrate	20 mg/ml	+	-
Methanol	10.0 %	+	-
Phenothiazine	200 g/ml	+	-
Phenylpropanolamine	200 g/ml	+	-
Salicylic Acid	200 g/ml	+	-

E. Reproducibility

In-House Evaluation











Four serum samples, spiked with PSA at the following concentrations, 0, 3, 5, 20 ng/ml, were tested in triplicate for twenty days, twice a day. All results obtained were 100% in agreement with the expected results. No within-run, between-run, within-day, or between-day discrepancy was observed.

Off-Site Evaluation

Reproducibility studies were also performed for INSTANT-VIEW[®] PSA Whole Blood/Serum Rapid Test at three physician's office laboratories (POL). Eighty (80) serum samples spiked with tPSA at four different concentrations, 20 negative, 20 at 2 ng/ml, 20 at 6 ng/ml, and 20 at 20 ng/ml, were evaluated. Each sample was run in triplicate for three days at each POL. All the intra-assay agreement, the inter-assay agreement, and the inter-site agreement were 100%.

REFERENCE

- Oeterling J.E.: J.Urol., 1991, 145:907-923.
- Lange pH.: The value of serum prostate specific antigen determinations before and after radical prostatectomy. J.Urol., 1989, 141:873-923.
- Starney TA.: Prostate specific antigen in the diagnosis and treatment of adenocarcinoma of the prostate untreated patients. J.Urol., 1989, 141:1070-1075.
- Schifman RB.: Analytical and physiological characteristics of prostate specific antigen and prostatic acid phosphatase in serum compared. Clin. Chem., 1987, 33:2086-2088.

 15°C - 35°C	Temperature limitation		Use by YYYY-MM
	Batch/Lot code		In vitro diagnostic medical device
	Manufacturer		Catalog number
	Contains sufficient for <n> tests		Consult instructions for use
	For IVD performance evaluation only		Do not reuse
	Caution, consult accompanying documents		

ALFA SCIENTIFIC DESIGNS INC.

POWAY, CA 92064 – USA
MADE IN USA

 7772

Distributed by: **CLIAwaived.com™**
San Diego, CA 92121
tel 858-481-5031
toll free 888-882-7739
www.cliawaived.com